

## E-328-2 Series AC Low Voltage Warning Relay, 10 Amps, 28 Vdc Contacts

### Product Facts

- DPDT
- Gasket sealed

### Performance Data

#### Electrical Characteristics

- Relay/Relay Driver**  
**Contact Arrangement** — DPDT  
**Rated Operating Voltage** — 28 Vdc  
**Resistive Rating** — 10 Amps  
**Inductive Rating** — 5 Amps  
**Lamp Rating** — 1.5 Amps

#### Coil Characteristics

**Duty Cycle** — Continuous

#### Voltage Sensor

- Operating Voltage, Nom.** — 115 V, 380-420 Hz  
**Pickup Voltage** —  $107 \pm 3$  Vrms  
**Dropout Voltage** —  $100 \pm 2$  Vrms  
**Dropout Time, Min.** — 40 msec

#### General Characteristics

- Temperature Range** —  $-55^{\circ}\text{C}$  to  $+85^{\circ}\text{C}$   
**Operating Cycles (Life)**  
**Mechanical, Min.** — 100,000 cycles  
**Weight, Max.** — 6 oz.

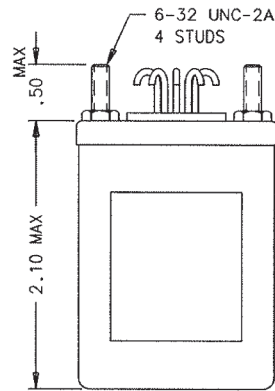
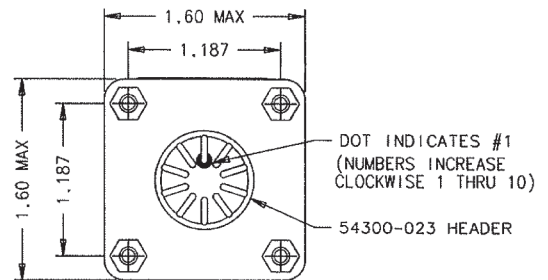

Mounting Style A

**Circuit Configurations** (Consult factory for other available circuit configurations)

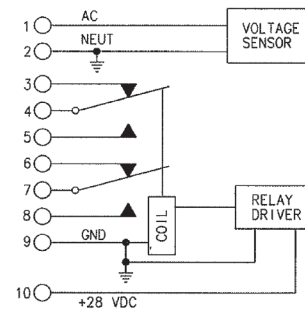

Circuit Configuration 1

For factory-direct application assistance, phone 419-521-9500 or fax 419-526-2749.

HARTMAN Part Number	Construction Type	Mounting Style	Coil Type	Circuit Config.	TE Part Number
E-328-2	Gasket/Vented	A	Continuous	1	1-1616126-8